

MULTI POINT OIL DISPENSER

“Save every drop of oil
to make a barrel of oil”

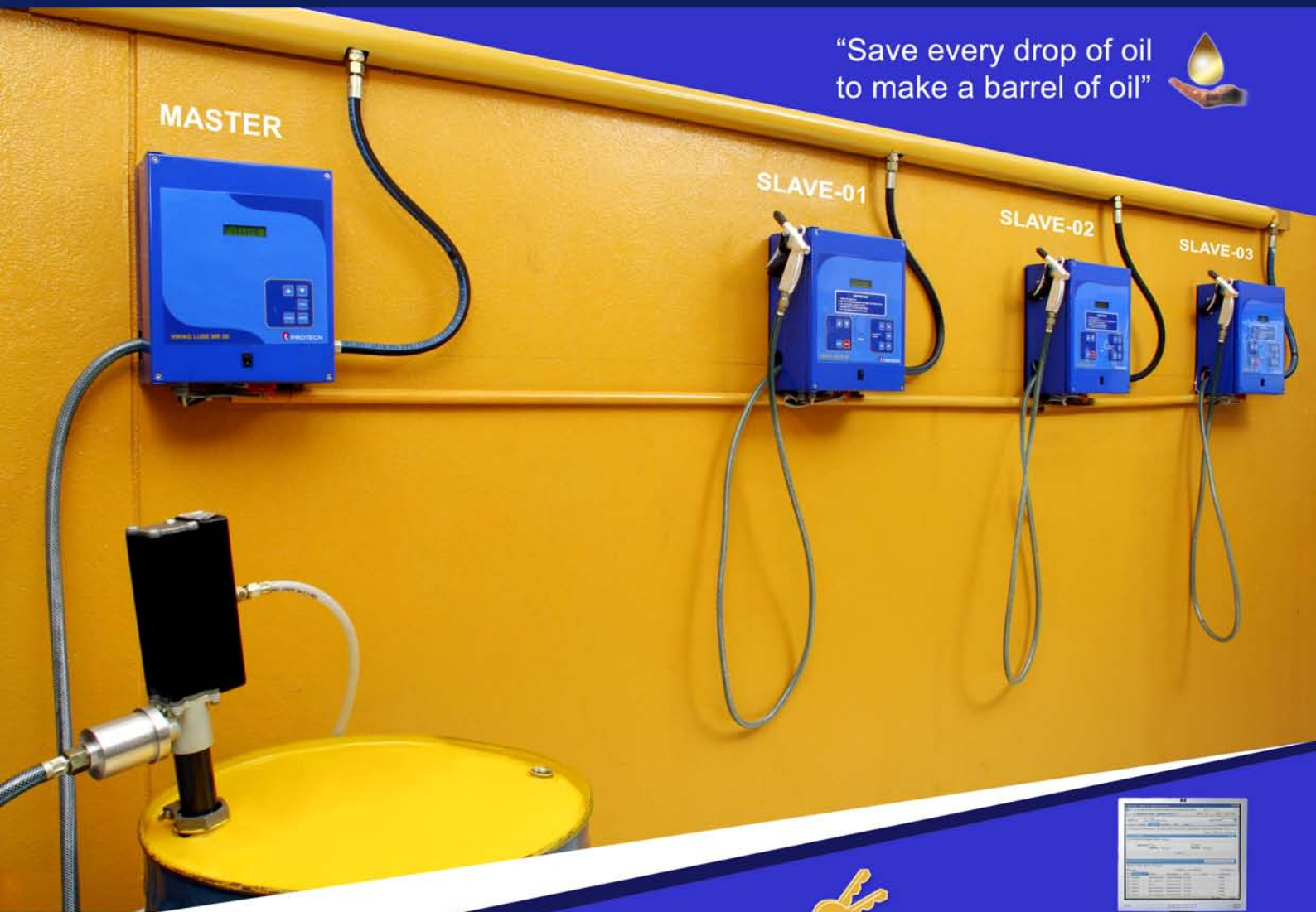

Secured Access



Lube Management
Software

- ▶ Drop to Drop Accountability
- ▶ Accurate
- ▶ Convenience
- ▶ Affordable

- ◆ Comprehensive record-keeping of all transactions
- ◆ Prevents loss of oil
- ◆ Helps in workshop Automation
- ◆ Secured access
- ◆ Multi-user facility
- ◆ Multi-Product usage
- ◆ Dispensing from the barrel to vehicle/bay



Viking Multipoint oil dispenser is specially designed for workshops and garages. This system dispenses the required quantity of oil directly in to the vehicle from the barrel. It uses one metering unit for multi point dispensing in master and slave concept. The master contains the metering unit and is networked with slaves for point dispensing. Each master can handle 50 slaves (i.e. 50 dispensing points). The required quantity is programmed at the slave, the data is sent to the master which in turn takes charge of that particular slave and dispenses the programmed quantity through that slave at the bay. Each slave has a facility for job no. entry & RFID card reader for technician identification (secured access). Each and every transaction is transferred to the computer, it maintains drop to drop accountability.

This type of system cuts the cost drastically for a multipoint lube dispensing in garages & workshops. Instead of multi metering units which is expensive. In this system only one metering unit is required (Master), and the balance are slaves which costs 25% of the master. Therefore there is a huge saving in cost

The Master & the slaves are networked electrically, a pipe line runs from the master to the slaves for supply of oil. The master and slaves can be kept up to 300mtrs apart

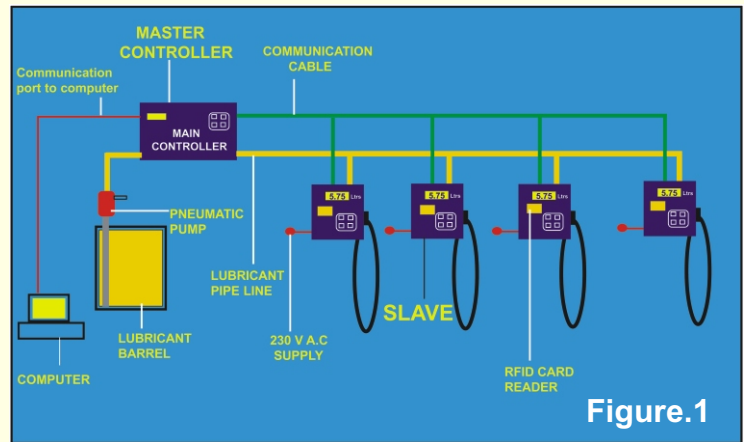

Master: The Master is a microprocessor based system It consists of a RS-485 communication Port, Oval Gear meter for metering with great accuracy, built in calibration, cumulative counter (for better accountability), a backlit LCD display & a keypad (life time warranty). It has a built in barrel empty indicator. Master has a facility to store 1,000 transactions and connectivity to computer. The master comes with a pneumatic pump which can be directly mounted on the barrel. (Can also handle multi product).

Slave: The slave is a microprocessor based system It consists of a RS-485 communication Port, dispensing counter (for better accountability) a backlit LCD display oil level low indicator, keypad: 5 programmable preset key & 4 control keys (life time warranty), a status indication lamp to indicate to the operator for the (availability and a Non drip nozzle). Each slave has a facility for job no. entry & RFID card reader. (Can also handle multi product).



The Lube Management software records online each & every transaction and it generates reports for drop to drop accountability of lube at the back office computer. It enables the workshop manager to have control over oil usage to prevent oil loss and to have comprehensive records at hand for accountability.

Advantages:

1. **Avoid Spillage**
Loss of LUBES in a garage is a minimum of 3%.
2. **Avoid excess dispensing.(accurate metering)**
3. **Drop to drop accountability of Lube.**
4. **Secured Access.**
5. **Better Housekeeping.(no spillage)**
6. **Time saving (Man hours saving, turn around).**
7. **Saving in Bulk Purchase of lube oil.**
8. **No Litter disposal (Packaged Oil).**
9. **Helps in workshop Automation**
10. **Multi user facility.**



Single/Multi Product Usage

Reduce



Turn around time

Avoid



Spillage

PROTECH

Progressive Technologies

An ISO 9001:2000 COMPANY

PLOT NO.46, ROAD NO.76, JUBILEE HILLS,
HYDERABAD - 500 033.

PH: 91-40-23554836, FAX: 91-40-23544276.

mail: protech@cityonlines.com, info@protech-india.com
www.protech-india.com